

# A Stable Self-Tuning Fuzzy Logic Control System for Industrial Temperature Regulation

Zhiqiang Gao and Thomas A. Trautzsch  
Department of Electrical Engineering  
Cleveland State University  
Cleveland, Ohio 44115  
gao@csvaxe.csuohio.edu

James G. Dawson  
Setech Inc.  
903 Industrial Dr.  
Murfreesboro, TN 37129

## Abstract

A closed loop control system incorporating fuzzy logic has been developed for a class of industrial temperature control problems. A unique fuzzy logic controller (FLC) structure with an efficient realization and a small rule base that can be easily implemented in existing industrial controllers was proposed. It was demonstrated in both software simulation and hardware test in an industrial setting that the fuzzy logic control is much more capable than the current temperature controllers. This includes compensating for thermo mass changes in the system, dealing with unknown and variable delays, operating at very different temperature setpoints without retuning, etc. It is achieved by implementing, in FLC, a classical control strategy and an adaptation mechanism to compensate for the dynamic changes in the system. The proposed FLC was applied to two different temperature processes and significant improvements in the system performance is observed in both cases. Furthermore, the stability of the FLC is investigated and a safeguard is established.

## I. Introduction

While modern control theory has made modest inroad into practice, fuzzy logic control has been rapidly gaining popularity among practicing engineers. This increased popularity can be attributed to the fact that fuzzy logic provides a powerful vehicle that allows engineers to incorporate human reasoning in the control algorithm. As opposed to the modern control theory, fuzzy logic design is not based on the mathematical model of the process. The controller designed using fuzzy logic implements human reasoning that has been programmed into fuzzy logic language (membership functions, rules and the rule interpretation).

It is interesting to note that the success of fuzzy logic control is largely due to the awareness to its many industrial applications. Industrial interests in fuzzy logic control as evidenced by the many publications on the subject in the control literature has created an awareness of its increasing importance by the academic community. Starting in the early 90s, the Applied Control Research Lab. at Cleveland State University, supported by industry partners, initiated a research program investigating the role of fuzzy logic in industrial control. The primary question at the time was: "What the fuzzy logic control does that the conventional control can not do?" The research results over the last few years have been reported in [1-5].

In this paper, we concentrate on fuzzy logic control as an alternative control strategy to the current proportional-integral-derivative (PID) method used widely in industry. Consider a generic temperature control application shown in Figure 1:

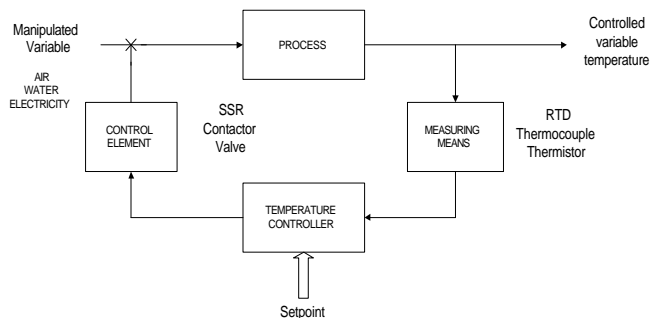

Figure 1: A typical industrial temperature control problem

The temperature is measured by a suitable sensor such as Thermocouples, Resistive Thermal Devices (RTD's), Thermistors, etc. and converted to a signal acceptable to the controller. The controller compares the temperature signal to the desired setpoint temperature and actuates the control element. The control element alters the manipulated variable to change the quantity of heat being added to or taken from the process. The objective of the controller is to regulate the temperature as close as possible to the setpoint.

To test the new fuzzy logic control algorithms, two temperature regulation processes were used in this research. One uses hot and cold water as manipulated variable and a valve as the controller element, the other uses electricity as a power source to a heater, actuated by a Solid State Relay (SSR). The new algorithms were tested extensively in both simulation and the hardware tests.

### A. Motivation

Currently, the classical PID (Proportional, Integral and Derivative) control is widely used with its gains manually tuned based on the thermal mass and the temperature setpoint. Equipment with large thermal capacities requires different PID gains than equipment with small thermal capacities. In addition, equipment operation over wide ranges of temperatures (140° to 500°), for example, requires different gains at the lower and higher end of the temperature range to avoid overshoots and oscillation. This is necessary since even brief temperature overshoots, for example, can initiate nuisance alarms and costly shut downs to the process being controlled. Generally, tuning the Proportional, Integral, and Derivative constants for a large temperature control process is costly and time consuming. The task is further complicated when incorrect PID constants are sometimes entered due to the lack of understanding of the temperature control process.

The difficulty in dealing with such problems is compounded with variable time delays existed in many such systems. Variations in manufacturing, new product development and physical constraints place the RTD temperature sensor at different locations, inducing variable time delays (dead time) in the system.

It is also well known that PID controllers exhibit poor performance when applied to systems containing unknown nonlinearity such as dead zones saturation and hysteresis. It is further understood that many temperature control processes are nonlinear. Equal increments of heat input, for example, do not necessarily produce equal increments in temperature rise in many processes, a typical phenomenon of nonlinear systems.

The complexity of these problems and the difficulties in implementing conventional controllers to eliminate variations in PID tuning motivate us to investigate intelligent control techniques such as fuzzy logic as a solution to controlling systems in which time delays, nonlinearities, and manual tuning procedures need to be addressed.

### B. The Time Delay Problem and Existing Solutions

To study the temperature control problem using classical control techniques, a simplified block diagram, in Figure 2, is used, instead of Figure 1, where  $C(s)$  represents the controller and  $G(s)e^{-st}$  the plant with a pure time delay of  $\tau$ . It is well known that the time delay makes the temperature loops hard to tune. The time delay problem may be characterized by *large* and *small* delays. A linear time invariant system with finite delay  $\tau$  can be modeled as  $G(s)e^{-st}$ , where  $G(s)$  is a rational transfer function of  $s$ . Note that the delay corresponds to a phase shift of  $-\omega\tau$ , where  $\omega$  denotes the frequency. Small phase shifts at frequencies of interest may be viewed as perturbations and incorporated into a delay free design with sufficient phase margin. A large delay is classified as a delay that significantly affects the stability and phase margins to the point that delay free design methods will not be sufficient.

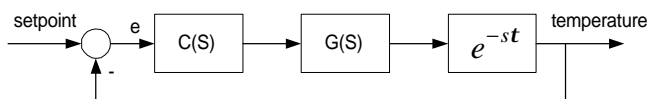

Figure 2: A Closed-loop Temperature Control System

A number of time delay compensation and prediction schemes have been developed and/or improved with modifications as shown in [7-12]. The performance of Smith Predictor Control (SPC) was studied experimentally in [8]. It shows that the system performs well if the process model is accurate, but that performance degrades rapidly with inaccuracy in the process parameters and time delay. Clearly for an unknown or variable time delay, Smith predictive compensation is no longer a viable technique.

Several control design methods for systems with varying time delays have appeared in recent literature including an estimation and self-tuning method proposed by Brone and Harris [10], a variable structure controller by Shu and Yan [11], and a model reference adaptive approach by Liu and Wang [6], to name a few.

For systems with large time delays, most design approaches use a prediction mechanism as part of the controller to

simulate the process for given system parameters and time delay. In the well known Smith predictor [7], the controller output is fed through models of the process with delay, and the process without delay, respectively. The difference of the output signals is added to the actual plant output and then fed back to the controller, thus allowing the controller to act on the prediction of the plant output.

Using this well known time delay compensation technique on a simple first order plant in an industry standard PID controller such as Bailey's Infi-90 single loop controller is still not an easy task. The predictor parameters including the plant gain, time constant, and time delay, in addition to the three PID parameters must be determined. These six parameters used in a predictive compensator increase tuning and operational complexity on even the simplest plants. The additional complexity of the Smith predictor is the main reason industry still uses nonpredictive PI or PID control for time delay using tuning methods such as Ziegler-Nichol's method.

### C. Fuzzy Logic Control

Fuzzy control is an appealing alternative to conventional control methods when systems follow some general operating characteristics and a detailed process understanding is unknown or traditional system models become overly complex [6]. The capability to qualitatively capture the attributes of a control system based on observable phenomena is a main feature of fuzzy control. These aspects of fuzzy control have been demonstrated in various research literature, see [13-15,18,19], and commercial products from vendors like Reliance Electric and Omron. The ability of fuzzy logic to capture system dynamics qualitatively, and execute this qualitative idea in a real time situation is an attractive feature for temperature control systems.

Of course, fuzzy logic control has its own limitations. The analytical study of fuzzy logic is still trailing its implementation and much work is still ahead, particularly in the area of stability and performance analysis. Furthermore, as solutions to practical problems, fuzzy logic control design is problem dependent and the adaptation of an exiting fuzzy logic controller to a different control problem is not straightforward. The available design tools, such as the Fuzzy Toolbox provided by Mathworks Inc., generally require further improvements before they become acceptable to control engineers.

In this paper, the validity of fuzzy logic control as an alternative approach in temperature control applications is investigated.

## II. Fuzzy Logic Control Design

The FLC developed here is a two-input single-output controller. The two inputs are the deviation from setpoint error,  $e(k)$ , and error rate,  $\Delta e(k)$ . The FLC is implemented in a discrete-time form using a zero-order-hold as shown in Figure 3a. The operational structure of the Fuzzy controller is shown in Figure 3b.

### A. Fuzzification/Defuzzification

Fuzzification and defuzzification involve mapping the fuzzy variables of interest to "crisp" numbers used by the control system. Fuzzification translates a numeric value for the error,  $e(k)$ , or error rate,  $\Delta e(k)$ , into a linguistic value such

as positive large with a membership grade. Defuzzification takes the fuzzy output of the rules and generates a "crisp" numeric value used as the control input to the plant.

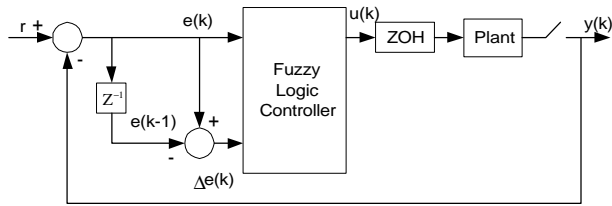

a) Closed-Loop FLC System

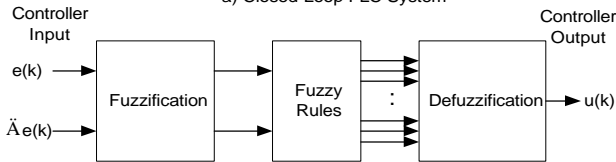

b) Structure of a Fuzzy Controller

Figure 3: Fuzzy Logic Control System.

The FLC membership functions are defined over the range of input and output variable values and linguistically describes the variable's universe of discourse as shown in Figure 4. The triangular input membership functions for the linguistic labels zero, small, medium, and large, had their membership tuning center values at 0, 0.2, 0.35, and 0.6, respectively. The universe of discourse for both  $e$  and  $\Delta e$  is normalized from -1 to 1. The left and right half of the triangle membership functions for each linguistic label was chosen to provide membership overlap with adjacent membership functions. The straight line output membership functions for the labels zero, small, medium, and large are defined as shown in Figure 4 with end points corresponding to 10, 30, 70, and 100% of the maximum output, respectively. Both the input and output variables membership functions are symmetric with respect to the origin.

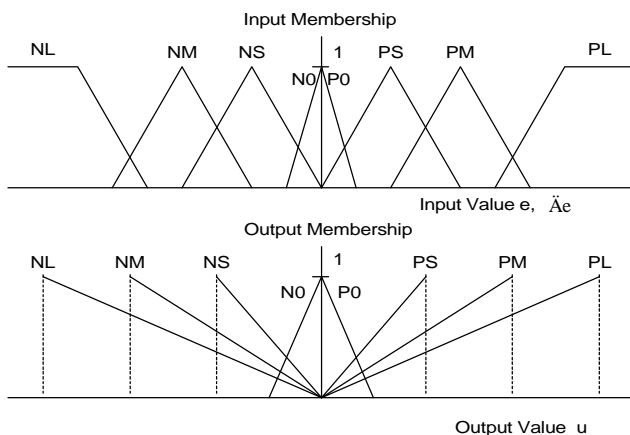

Figure 4: Fuzzy Membership Functions

Selection of the number of membership functions and their initial values is based on process knowledge and intuition. The main idea is to define partitions over the plant operating regions that will adequately represent the process variables

## B. Rule Development

Our rule development strategy for systems with time delay is to regulate the overall loop gain to achieve a desired step response. The output of the FLC is based on the current input,  $e(k)$  and  $\Delta e(k)$ , without any knowledge of the previous input and output data or any form of model predictor. The main idea is that if the FLC is not designed with specific knowledge of mathematical model of the plant, it will not be dependent on it. The rules developed in this paper are able to compensate for varying time delays on-line by tuning the FLC output membership functions based on system performance.

The FLC's rules are developed based on the understanding of how a conventional controller works for a system with a fixed time delay. The rules are separated into two layers: the first layer of FLC rules mimics what a simple PID controller would do when the time delay is fixed and known; the second rule layer deals with the problem when the time delay is unknown and varying.

In developing the first layer rules, consider the first order plant,  $G(s)e^{-s\tau}$ , where  $G(s)=a/(s+a)$ . In the PID design, the following assumptions are made:

- The time delay  $\tau$  is known
- The rise time,  $t_r$ , or equivalently, the location of the pole is known.
- $t_r$  is significantly smaller than  $\tau$
- The sampling interval is  $T_s$

The conventional PI-type controller in incremental form is given by:

$$u(k) = u(k-1) + f(e, \Delta e) \quad (1)$$

where  $f(e, \Delta e)$  is computed by a discrete-time PI algorithm. This control algorithm was applied to a first order plant with delay. Initial tuning of PI parameters was carried out by using the Ziegler-Nichols method. The step response obtained has about a 20% overshoot for a fixed time delay.

Next a fuzzy logic control law was set up where  $F(e, \Delta e)$ , the output of the FLC for the  $k^{\text{th}}$  sampling interval, replaces  $f(e, \Delta e)$  in the incremental controller described in (1). The rules and membership functions of the FLC were developed using an intuitive understanding of what a PI controller does for a fixed delay on a first order system. They generalized what a PI controller does for each combination of  $e$  and  $\Delta e$  in 12 rules as shown in Table 1.

Table 1: FLC Control Rules

		$\Delta e$							
		NL	NM	NS	NO	PO	PS	PM	PL
e	NL	NL							
	NM	NM				PS			
	NS			NM	PS				
	NO	NO							
	PO	PO							
	PS			NS	PM				
	PM	NS		PM					
	PL	PL							

Shaded Areas Represent Zero Control Action

The output from each rule can be treated as a fuzzy singleton. The FLC control action is the combination of the output of each rule using the weighted average defuzzification method and can be viewed as the center of gravity of the fuzzy set of output singletons.

### C. Tuning of Membership Functions in Design Stage

Since there is little established theoretical guidance, the tuning of rules and membership functions in the design stage is largely an iterative process based on intuition. The membership functions were tuned subject to the stability criteria derived later in Section IV, based on observations of system performance such as rise time, overshoot, and steady state error.

The number of membership functions can vary to provide the resolution needed. Note that the number of rules can grow exponentially as the number of input membership functions increases. The input membership functions for  $e$  and  $De$  generate 64 combinations which can be grouped into twelve regions corresponding to each rule in Table 1.

The center and slopes of the input membership functions in each region is adjusted so that the corresponding rule provides an appropriate control action. In case when two or more rules are fired at the same time, the dominant rule, that is the rule corresponding to the high membership grade, is tuned first. Modifying the output membership function adjusts the rules contribution relative to the output universe of discourse. Once input membership rule tuning is completed, fine-tuning of the output membership functions is performed to achieve the desired performance.

Although this FLC is constructed based on the assumption that the time delay is fixed and known, the only element of the controller that is a function of the delay is the universe of discourse for the output. It is shown below that with some adjustment and extra rules, the FLC can be made to adapt to an unknown nature or change in delay.

### D. Self-Tuning

The FLC structure presented above can be directly modified to compensate for changes in the plant dynamics and variable time delays by adding a second layer of self-tuning rules to the FLC. Due to the page limit, the discussion is limited to adding the self-tuning function to the FLC in the presence of variable time delay. More details on self-tuning can be found in [1,2].

In the case of varying time delay, the FLC gain must be adjusted to offset the effects of the changes in delay. It will be shown in Section IV that the maximum gain or control action is inversely proportional to the time delay. Therefore, if the delay increases, we should decrease the FLC gain to reduce the control action, and vice versa. Based on this relationship, the system performance can be monitored by a second layer of rules that adapts the output membership functions of the first layer of rules to improve the performance of the fuzzy controller.

Consider an output membership function tuned for a nominal delay. When the true system time delay is larger than the nominal delay, the control action determined by the nominal delay causes the control output to be too large for the true system. This condition effectively increases the controller gain, and as the difference between the true and nominal delay becomes large, system stability problems could arise. Conversely, when the true delay is smaller than

the nominal delay, the controller gain will be too small and the system becomes sluggish.

The output membership functions (see Figure 4) of the FLC are defined in terms of the maximum control action. A viable mechanism to compensate for a varying time delay is to adjust the size of the control action under the assumption that the number of control rules remains fixed and the linguistic control strategy is valid for different values of time delay. These conditions are reasonable given the plant parameters are known and that the control strategy developed is based on a plant with delay.

To adjust the FLC on-line for systems with varying time delay, a second layer of six rules was added as an adaptation mechanism to modify the output membership function used by the first layer rules with a scaling factor. This effectively changes the FLC control output universe of discourse (i.e., the maximum control action) based on system performance. These rules adjust the FLC output based on rise time and overshoot. The overshoot is monitored and classified as large (L), medium (M), and small (S). It is observed that changes in overshoot is indicative of a change in time delay. A longer delay results in a larger overshoot. Such effects can be alleviated by reducing the output scaling factor appropriately. Rise time performance is classified as Very Slow (VS), Medium Slow (MS), and Slightly Slow (SS), and an increase in the output scaling factor can help to speed up the response.

The design strategy for the second layer of rules is based on two different aspects of tracking performance, i.e., rise time and overshoot calculated from  $(e, De)$ . The second layer rules are listed in Table 2. They monitor the plant response and reduce or increase the FLC controller output universe of discourse. The fuzzy membership functions are defined using a membership configuration similar to the control strategy in Figure 3. The adjustment rules perform two actions; they reduce the FLC gain when the plant is significantly overshooting the desired response, and increase the gain when rise time performance is slow.

*Remark:* A unique fuzzy control system is presented in this section. Although a PI controller is used as a guideline for setting up the FLC, it by no means limits its ability to perform more complicated tasks. Similar approaches can be used to set up a FLC that mimics more complex controllers. The emphasis here, however, is to deal with unknown dynamics and variable time delay problems which we have difficulty with using analytical approaches.

Table 2: FLC Output Adjustment

Rise Time Rules If Tracking is $L_1$ then Adjust is $L_2$		Overshoot Rules If Overshoot is $L_3$ then Adjust is $L_4$	
$L_1$	$L_2$	$L_3$	$L_4$
SS	PS	L	NL
MS	PM	M	NM
VS	PL	S	NS

## III. Software Simulation

The FLC developed above was simulated for the tank temperature control system shown below in Figure 5. The temperature of the tank fluid with constant flow rates in and out is to be controlled by adjusting the temperature of the

incoming fluid. The incoming fluid temperature is determined by a mixing valve which controls the ratio of hot and cold fluid in the supply line to the tank. The distance between the mixing valve and the supply line discharge to the tank illustrates the classic material transport delay in pipes. The temperature/pressure of the fluids will also affect the delay.

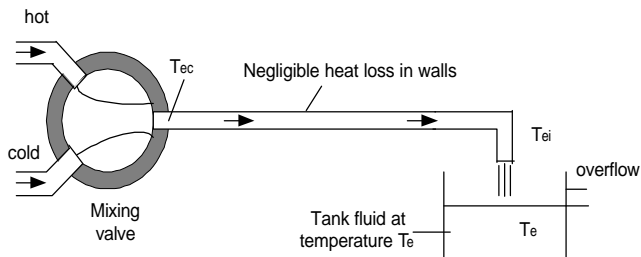

Figure 5: Tank Temperature Control

The transfer function for the tank temperature control problem in Figure 5 is given by:

$$G(s) = \frac{T_e(s)}{T_{ec}(s)} = \frac{e^{-st}}{s/a + 1} \quad (2)$$

where  $T_e$  = tank temperature;  $T_{ec}$  = temperature at exit of mixing valve;  $\tau$  = time delay for material transport in the pipe  $a = \dot{m}/M$ ,  $\dot{m}$  = mass flow rate ( $=\dot{m}_{in}=\dot{m}_{out}$ ), and  $M$  = fluid mass contained in the tank. More details of this problem can be found in [22].

#### A. Simulation Results

The FLC was applied to the plant described in equation (2) with  $a=1$ . Assuming the hot and cold supply enters the mixing valve at a constant pressure, the time delay from the material transport will also be constant. Conversely, if the hot and cold supply pressure is varying, the transport delay will also vary. The variable time delay aspects of this system are investigated in the following simulations.

The simulation results are obtained using an 18 rule FLC, the 12 first layer rules in Table 1 provide the control strategy, and the six second layer rules in Table 2 adjust the control output membership function universe of discourse based on the system performance. For comparison purposes, simulation plots include a conventional PID controller, a Smith Predictor Control (SPC), and the fuzzy algorithm. The PID, SPC, and FLC were tuned on the plant with a 10 second time delay with the response shown in the top plot of Figure 6. As expected, the SPC has the fastest response in the presence of an accurate plant model and a known time delay, but the PID and FLC provide good performance in terms of rise time and overshoot in the absence of a prediction mechanism. The middle and bottom plot of Figure 6 shows how the controllers react as the true system time delay increases from the nominal 10 second delay used to tune the controllers. The FLC algorithm adapts quickly to longer time delays and provides a stable response while the PID controller drives the system unstable and the SPC oscillates around a final value due to the mismatch error generated by the inaccurate time delay parameter used in the plant model.

From the simulations, clearly the SPC provides the best response with an accurate model of the plant and delay. In the presence of an unknown or possibly varying time delay, the proposed FLC shows a significant improvement in

maintaining performance and preserving stability over standard SPC and PID methods.

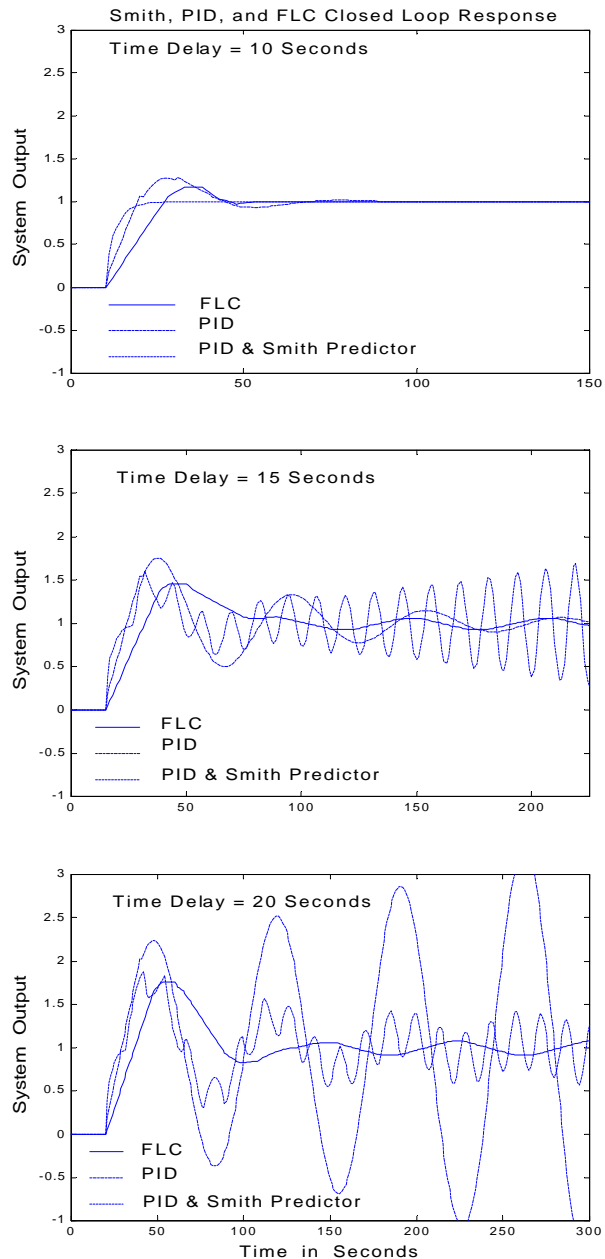

Figure 6: PID, SPC, and FLC Comparison

#### IV. Stability Analysis

Most proposed FLCs in literature do not have any stability proof because of the difficulty in analysis. However, for the FLC to be considered as a serious contender in industrial control design, a measure of stability or a certain degree of safety must be provided. Noting that the FLC can be viewed as a nonlinear time-varying controller, the stability issue is addressed below.

Consider a SISO fuzzy logic control system where the FLC control law is given as  $\phi(e)$ , where  $\phi(e)$  is a memory less nonlinear function of  $e$ . The FLC developed above can be viewed as a nonlinear integral controller with a variable gain. We are interested in developing constraints on  $\phi(e)$  such that

the closed loop system is globally stable. For the sake of convenience, the FLC system in continuous time, shown in Figure 7, is used for the analysis.

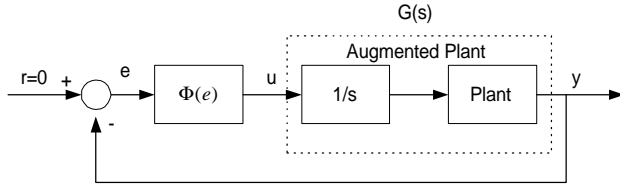

Figure 7: System Structure for Stability Analysis

Assume that the state space representation of the augmented plant is given by

$$\begin{aligned} \dot{x} &= Ax + Bf(e) \\ y &= Cx \end{aligned} \quad (4)$$

where  $A$  is Hurwitz, and  $[A \ B \ C]$  is a minimal realization of  $G(s)$ . Note that Figure 7 and the system equations (4) describe a classical nonlinear stability problem. Next the Popov Method is used to derive stability conditions for the proposed FLC which can be used as a guideline to help set up the fuzzy controller.

The Popov Method states that a system described by (4) is absolutely stable for all nonlinearities  $\varphi(e) \in (0, k)$  if there exists a strictly positive number  $\alpha$  such that for

$$\forall \omega \geq 0 \quad \text{Re}[(1 + j\omega)G(j\omega)] + \frac{1}{k} \geq 0 \quad (5)$$

the origin is globally asymptotically stable. The Popov Method provides the stability guarantee of (5) using a quadratic Lyapunov function. Therefore, for a strictly positive  $\alpha$ , a bound on  $k$  can be found to ensure the derivative of the Lyapunov function is negative and the system in (4) is absolutely stable. More details may be found in [14] and [15].

To carry out the stability analysis, the first order Padé approximation for  $e^{-st}$  is used, which is given by  $e^{-st} \approx (1 - s\tau/2)/(1 + s\tau/2)$ . Using the Popov Method we will determine the sector condition on  $\varphi(e)$  such that the system is absolutely stable. Rewriting the augmented plant with the Padé approximation in the form  $G(j\omega) = G_1(\omega) + jG_2(\omega)$  we have

$$\begin{aligned} G(j\omega) &= \frac{1}{j\omega} \frac{a}{(j\omega + a)(1 + j\omega t/2)} \\ &= \frac{-a\omega(1 + at - \omega^2 t^2/4) - ja(a - \omega^2 t/2(2 + at/2))}{\omega[a^2 + \omega^2(1 + a^2 t^2/4) + \omega^4 t^2/4]} \end{aligned} \quad (6)$$

Substituting (6) into (5), the Popov inequality becomes

$$\begin{aligned} \frac{1}{k} \frac{1}{a} (a^2 + \omega^2(1 + a^2 t^2/4) + \omega^4 t^2/4) \\ > 1 + at - aa + a\omega^2 t/2(2 + at/2) - \omega^2 t^2/4 \end{aligned} \quad (7)$$

through straightforward, but rather tedious manipulations, (7) is reduced to

$$\begin{cases} \frac{1}{k} > t - a + \frac{1}{a} = x_1 \\ \frac{1}{k} > \frac{at/2[a(2 + at/2) - t/2]}{1 + a^2 t^2/4} = x_2 \end{cases} \quad (8)$$

That is, for a first order system with delay described by equation (4) and Figure 7, the sector condition,  $\varphi(e) \in (0, k)$ , to maintain absolute stability for a time delay  $\tau$  is given by:

$$\frac{1}{k} > \max(x_1, x_2) \quad (9)$$

Note that the stability constraint in (9) is a function of  $\tau$ ,  $a$ , and  $\alpha$ , where  $\tau$  and  $a$  are parameters of the plant and  $\alpha$  is any positive real number. For example, if we let  $\alpha = 1/a$ , then from (8)  $x_1 = \tau$ , and  $x_2 = \tau/(1 + a^2 \tau^2/4)$ . Using equation (9) now gives the value  $k < 1/\tau$  as the maximum gain to guarantee stability. In general, if the range of  $\tau$  and  $a$  are known, a maximum bound on  $k$  can be determined by varying  $\alpha$  iteratively and determining  $\min_{t, a, \alpha}(\max(x_1, x_2))$ .

*Remark:* The bound in (9) guarantees the asymptotic stability of the system. That is the derivative of a certain quadratic Lyapunov function [14,15] is strictly negative. Because of the conservative nature of the Lyapunov approach, (9) may be too restrictive for practical implementation. Our approach is to enforce the sector condition as a stability safeguard in the large error region while in the low to intermediate error range the FLC is tuned to provide good tracking performance. This strategy proves to be quite successful in the simulations shown in Section III. The tradeoff is that the origin of the system is not necessarily asymptotically stable. However, the error is guaranteed to be bounded. The proof is rather straightforward. As the error becomes "large," as defined in the membership function, the corresponding FLC gain, designed subject to (9), forces the derivative of the Lyapunov function to be strictly negative, and therefore the error to reduce.

## V. An Industrial Application

The fuzzy logic control temperature control scheme is further tested in an industrial application where several components in a machine have to be temperature regulated. These components are of different thermo mass and may be regulated at different temperatures. Currently, a separate PID controller is tuned for each component at each temperature setpoint, which is quite labor intensive. Furthermore, the PID parameters need frequent adjustments due to the changes in operating conditions. The goal of fuzzy control is to replace this set of PID controllers with one self-tuning fuzzy controller and to eliminate the needs for further tuning, once the machine is in operation.

### A. Hardware Setup

A generic diagram of the process that applies to all components of the machine is shown below:

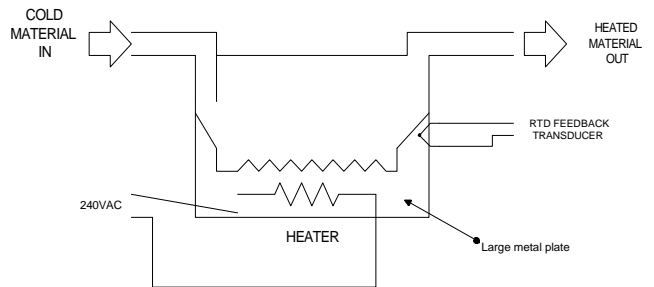

Figure 8: An Industrial Temperature Control Application

This heating equipment of high temperature liquids has a large thick metal plate on the underside of the tank between the bottom and the inside of the tank, as shown in Figure 8. It can be shown that this is a second order system with two

thermal time constants. The first one corresponds the thermal resistance from the heater to the plate and the plate heat capacity [1]. The second one comes from the thermal resistance of the plate to the material and the heat capacity of the material.

There are many variations in the dynamics of the system. The thermo capacity is proportional to the size of the tank, which is quite different from one component to another. The time delay in the system is quite sensitive to the placement of the RTD. The heater can be found to be undersized or oversized.

The heater on and off is controlled by a 24V pulse width modulated (PWM) signal applied to the SSR, as show in Figure 9.

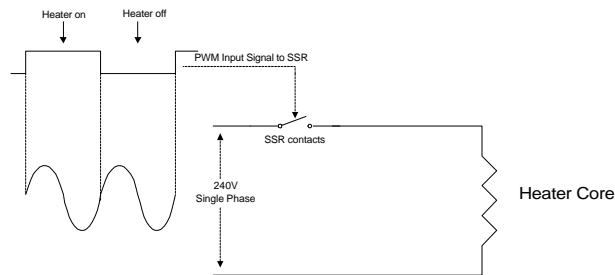

Figure 9: Heater Excitation

### B. Distributed Control Implementation

The digital control system includes a local microprocessor as well as a host processing system in a configuration known as *distributed control*. Here, the host processor is a Pentium computer executing the fuzzy logic temperature control algorithm, and the local processor is the Temperature Control Node (TCN). The host processor and the TCN pass two variables: The process temperature and the heater *on time* count (see Figure 10). The TCN communicates over a communications network to the host processor using a Dynamic Data Exchange (DDE) interface. The DDE interface defines a standard way for Microsoft Window applications to share information with one another.

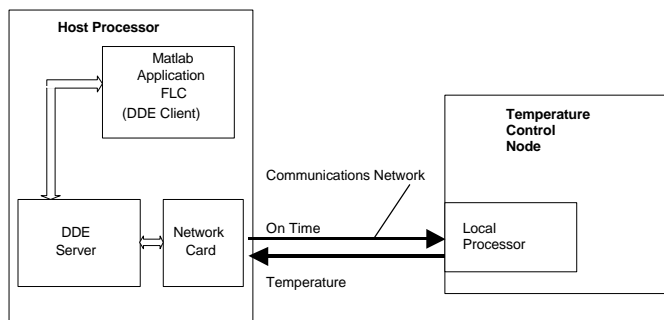

Figure 10: Distributed Control

The entire closed loop control is a result of the two microprocessors executing their respective software applications and communicating with each other in a defined time interval. The host processor receives the process temperatures while supplying the appropriate heater *on time* to the temperature control node. The local microprocessor in the TCN executes the application code which defines the

local timing for reading the feedback temperatures and turning on the solid state relays (see Figure 11).

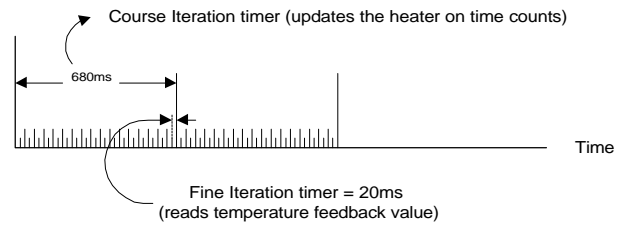

Figure 11: Local Processor Timing

The design of a temperature control is primarily governed by two criteria: 1) How fast does the controller need to measure temperature? 2) to what degree of accuracy does the temperature need to be maintained?. The data acquisition of temperature is designed based on answers to the above criteria. The time constant, for example, of high temperature thermal processes is large; thus, the temperature does not need to be sampled very fast. This simplifies the overall hardware architecture to what is commonly known as a *Centralized Data Acquisition System* (CDAS). The CDAS architecture uses a reduced number of integrated circuits (IC's) that results in an overall lower product cost. The temperature CDAS is a sampled data system that consists of RTD analog sources and their excitation, a centralized analog time switching system (i.e. multiplexer), a single Analog to Digital Converter (ADC), and a serial computing microprocessor (See Figure 12). In short, the temperature control node uses a CDAS to read the temperature feedback and then applies an appropriate output control action (heater *on time*) to maintain the process temperature.

### C. Fuzzy Logic Controller Adjustments

Because this industrial temperature process is quite different from the one studied previous study, shown in section II and III, the fuzzy logic controller must be adjusted accordingly. In particular, the membership functions are shown in Table 3, the rule base is in Table 4.

Table 3 Membership Functions

e Triangular Fuzzy Membership Values				Δ e Triangular Fuzzy Membership Values			
e Membership	a <sub>1</sub>	a <sub>2</sub>	a <sub>3</sub>	Δ e Membership	a <sub>1</sub>	a <sub>2</sub>	a <sub>3</sub>
PL	4.5	6	∞	PL	.8125	1	∞
PM	1	3	5.5	PM	.5	.625	1
PS	.02	.8	1.5	PS	.125	.343	.562
PO	-.0001	0	.03	PO	.00625	.1	.187
NO	-.03	0	.0001	Z	-.0125	0	.0125
NS	-1.5	-.8	-.02	NO	-.187	-.1	-.00625
NM	-5.5	-3	-1	NS	-.562	-.343	-.125
NL	-∞	-6	-4.5	NM	-1	-.625	-.5
				NL	-∞	-1	-.8125

Furthermore, additional rules were added to make the controller automatically adjust itself to the different dynamics of the processes. This includes the mechanism that adjust the universe of discourse based on the initial slope of the temperature curve, which is indicative of the time constant of

the system. Also included are rules that automatically tune the controller based on overshoot and the setpoint values. The details can be found in [2].

Table 4 : FLC Rule Base as Percentage of *On time* Adjustment

		$\Delta e$								
		NL	NM	NS	NO	Z	PO	PS	PM	PL
e	NL	-100								
	NM	-100					-72			
	NS	-100	-72	-10	40					
	NO	-10								
	PO	10								
	PS	-100	-40	10	72		100			
	PM	-100	-72	-40	72	100				
	PL									

#### D. Hardware Test Results

The proposed fuzzy control algorithm was compared experimentally with the existing PID control used in industry. In this application, it is important to prevent overshoots which seriously affect the quality of the product. It is also desirable to have a smooth control signal that does not require excessive on and off actions in the heater.

The results are shown in Figure 12-15. The top portion of each figure is a comparison of the PID vs. Fuzzy temperature response, while the bottom portion is their respective heater *on times*. The Temperature Control Node was used to control the process for both controllers under the same conditions (i.e. same ambient temperature, delays, etc.). The results were obtained by actually controlling the process in its industrial setting.

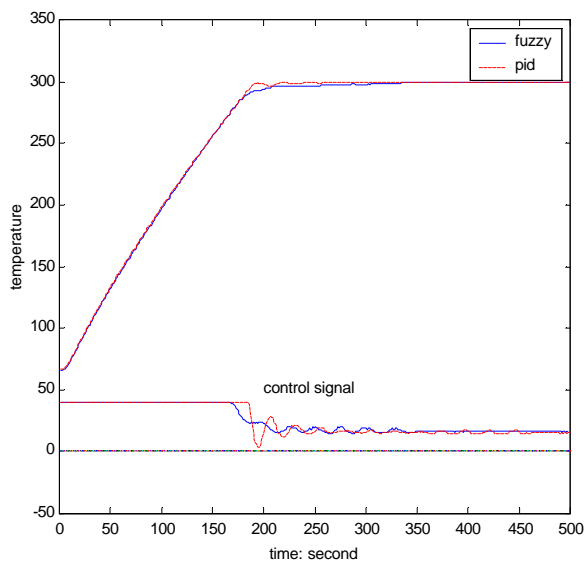

Figure 12: PID and Fuzzy Controller at High Temperature

The comparison of the performance of the FLC and PID controllers was performed under different setpoints, different thermal mass and different time delays. In each case, the

FLC was able to successfully meet all design specifications without operator's tuning. On the other hand, it is a standard practice that for each of these different testing conditions, the PID controller needs to be manually tuned. Otherwise, the resulting response produced by PID controller would usually be unsatisfactory, as can be seen in Figure 12-15.

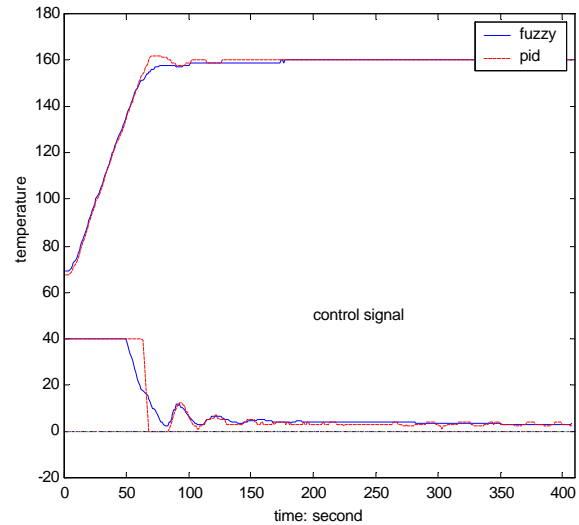

Figure 13: PID and Fuzzy Comparison at Low Temperature

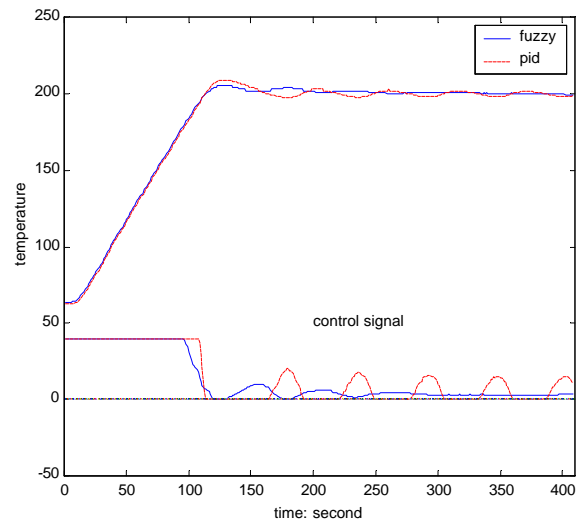

Figure 14: PID and Fuzzy Comparison with Time Delay

In summary, a practical FLC has been developed, with marked advantages over the PID controller. The FLC utilizes self-tuning mechanisms to effectively overcome issues not easily addressed in the PID controller. The "self-tuning" mechanisms of the FLC are not "all encompassing" but compensate for issues tested in this research. The flexibility associated with the FLC, however, would easily allow the controller to be expanded into a full range self-tuning control, should it become necessary



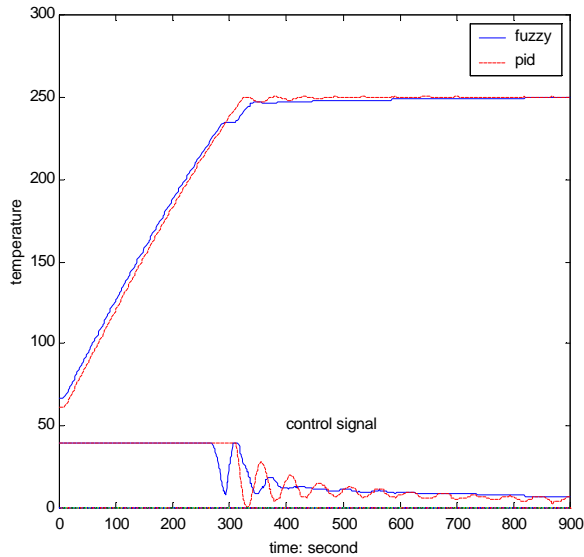

Figure 15: PID and Fuzzy Comparison with Large Thermo Mass

### VI. Conclusion

Unlike some fuzzy controllers with hundreds, or even thousands, of rules running on dedicated computer systems, a unique FLC using a small number of rules and straightforward implementation is proposed to solve a class of temperature control problems with unknown dynamics or variable time delays commonly found in industry. Additionally, the FLC can be easily programmed into many currently available industrial process controllers. The FLC was first simulated on a tank temperature control problem with promising results. Then, it was applied to an entirely different industrial temperature apparatus. The results show significant improvement in maintaining performance and stability over the widely used PID and SPC design method. The FLC also exhibits robust performance for plants with significant variation in dynamics. The stability characteristics were investigated and a stability safeguard was derived.

### References

[1] James Dawson, "Fuzzy Logic Control of Linear Systems with Variable Time Delay," M.S. Thesis, Cleveland State University, June 1994.  
 [2] Thomas A. Trautzch, "Self-Tuning Temperature Control Using Fuzzy Logic", M.S. Thesis, Department of Electrical Engineering, Cleveland State University, June 1996  
 [3] David J. Elliott, "Fuzzy Logic Positional Servo Motor Control Development Platform", M.S. Thesis, Department of Electrical Engineering, Cleveland State University, June 1997.  
 [4] Wilfred Nonnenmacher, "Fuzzy Logic Position Control of a Servo Motor", M.S. Thesis, Department of Electrical Engineering, Cleveland State University, April 1997.  
 [5] Nitin Dhayagude, Zhiqiang Gao and Fouad Mrad, "Fuzzy Logic Control of Automated Screw Fastening", *Journal Robotics and Computer Aided Manufacturing*, Vol. 12, No.3 pp. 235-242, 1996  
 [6] K. Passino and S. Yurkovich, *Fuzzy Control*, Addison-Wesley, 1998.

[7] O.J.M. Smith, "A Controller to Overcome Dead Time" *ISA Journal*, No. 2,28, February 1959.  
 [8] P.S. Buckley, "Automatic Control of Processes with Dead Time," *Proc. IFAC World Congress*, Moscow, 1960, p33-40.  
 [9] J.E. Marshall, "Control of Time Delay Systems," Stevenage, UK; NY P. Peregrinus, c1979.  
 [10] Q. Brone, and S. Harris, "Varying Time Delay Estimation and Self-Tuning Control," *Proceedings from the 1991 American Controls Conference*, v2, p1740-1741.  
 [11] K. Shu, and J. Yan, "Robust Stability of Uncertain Time Delay Systems and its Stabilization by Variable Structure Control," *Int. Journal of Control*, 1993, v57 n1, p237-246.  
 [12] G.P. Lui, and H. Wang, "Adaptive Controller for Continuous-Time Systems with Unknown Varying Time Delay," 1991 *Int. Conf. of Cont. IEE Conf. Pub.* v2, n332, p1084-1088.  
 [13] C.C. Lee, "Fuzzy Logic in Control Systems: Fuzzy Logic Controller -- Parts 1 & 2" *IEEE Trans. on Sys. Man, and Cybernetics*, Vol 20, No.2, pp404-435 March/April 1990.  
 [14] P.J. King, and E.H. Mamdani, "The Application of Fuzzy Control Systems to Industrial Processes," *Automatica*, v11, p235-242, 1977.  
 [15] S. Chiu, S. Chand, D. Moore, and A. Chaudhary, "Fuzzy Logic for Control of Roll and Moment for a Flexible Wing Aircraft", *IEEE Cont. Sys. Mag.* Vol. 11, No. 4, '91, pp42-48.  
 [16] J.A. Bernard, "Use of a Rule-Based System for Process Control", *IEEE Cont. Sys. Mag.* pp3-13, October 1988.  
 [17] J. Litt, "An Expert System to Perform On-Line Controller Tuning", *IEEE Cont. Sys. Mag.* pp18-23, April 1991.  
 [18] S. Tzafestas, and N. Papanikolopoulos, "Incremental Fuzzy Expert PID Control," *IEEE Trans. on Industrial Electronics*, Vol. 37, pp365-371, October 1990.  
 [19] P. Oliveria, P. Lima, and J. Sentierio, "Fuzzy Supervision of Direct Controllers," *Proc. 5th IEEE International Symposium on Intelligent Control*, pp638-643, 1990.  
 [20] J. Slotine, W. Li, "Applied Nonlinear Control," Prentice Hall, Englewood Cliffs, NJ, c1991.  
 [21] R.R. Mohler, "Nonlinear Systems: Volume I, Dynamics and Control," Prentice Hall, Englewood Cliffs, NJ, c1991.  
 [22] G.F. Franklin, "Digital Control of Dynamic Systems," Addison-Wesley Publishing, c1990.  
 [23] The Gulton Company, "Measurement and Control", Bulletin 523, p1-7, May 1980.